

uni Flex Plastic Chain

Series **uni 2500** Type -

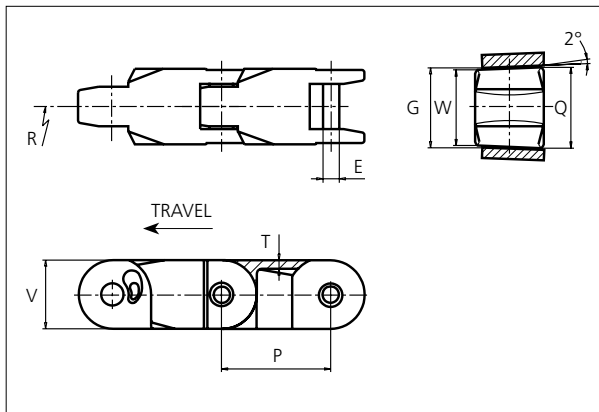

uni Flex Plastic Chain
 Side flexing chain
 Pitch: 63.5 mm (2.50 in)
 Backflex radius: 75.0 mm (3.00 in)
 Permissible tensile strength:
 POM material 7500 N (1686 lbf)

 Delivery: 6.1 m (20.0 ft)
 No. of links/box: 96

E		G		P		Q		T		V	
mm	in	mm	in	mm	in	mm	in	mm	in	mm	in
9.5	0.37	46.4	1.83	63.5	2.50	47.0	1.85	5.0	0.20	40.0	1.57

All dimensions are for chains in POM material.

Width (W)		Material & color	Pin material	Weight		Min. radius (R)	
mm	in			kg/m	lb/ft	mm	in
44.0	1.73	POM-D W	SS304	2.0	1.34	600.0	23.62

Non standard material and color: See uni Material and Color Overview.

Non standard pin material: See uni Material and Color Overview.

Accessories

Rubber Top/NON STANDARD

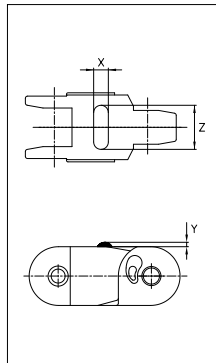

When ordering, please state the required distance between the Rubber Top.

Other Non Standard rubber profiles:
 See uni Rubber Profile Overview

Link material	Rubber material	Z		X		Y	
		mm	in	mm	in	mm	in
POM-D W	05 I	30.0	1.18	10.0	0.39	3.0	0.12

STANDARD

SIDE FLEXING

PITCH 63.5 MM/2.50 IN

Any questions? Please contact us.

Sprocket

No of teeth	Pitch diameter		Overall-diameter		Min. ø bore		Max. ø bore		Hub-diameter		A-dimension		B-dimension		Molded PA66 LG	Machined PA66 
	mm	in	mm	in	mm	in	mm	in	mm	in	mm	in	mm	in		
Z6	126.7	4.99	136.0	5.35	20.00	0.8	40.00	1.6	63.00	2.5	35.00	1.4	83.30	3.3		x
Z8	165.7	6.52	176.0	6.93	20.00	0.8	40.00	1.6	73.50	2.9	56.70	2.2	102.80	4.0		x
Z15	305.3	12.02	317.4	12.50	20.00	0.8	40.00	1.6	73.50	2.9	129.40	5.1	172.70	6.8		x

Non standard material and color:
See uni Material and Color Overview.

Machined sprocket

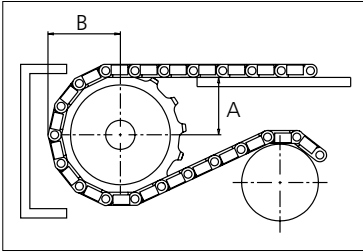

Please ensure that sufficient size shaft and keyway are chosen for corresponding load.

Other sprocket sizes are available upon request
Width of tooth: 11.0 mm/0.43 in
Width of sprocket: 42.3 mm/1.66 in
uni Retainer Rings: See uni Retainer Ring data sheet

Any questions? Please contact us.